



Horizontal Split Cast Pumps

LN Series

Double Volute
Single Stage



LN Series Horizontal Split Case Pumps

The LN Pumps versatile centrifugal double volute design minimises radial thrust problems and allows the pump to be operated at any capacity – from design point back to shut off – without harmful effects from excessive deflection. It is essentially a low deflection machine: Shaft and casing are all engineered to minimise deflection and consequent vibration, rubbing and wear.

For compactness, economy, and ease of installation, either side or bottom suction with side discharge is available. This flexibility is achieved without adversely affecting hydraulic performance. Suitable for motor, engine, or turbine drive. Available in various materials of construction.

Application Versatility

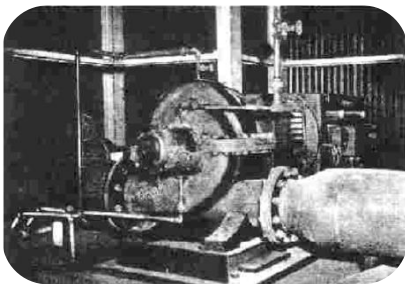

Steel mills - service water, roll cooling, strip colling, blast furnace cooling tower, BOF Gas clean-up systems

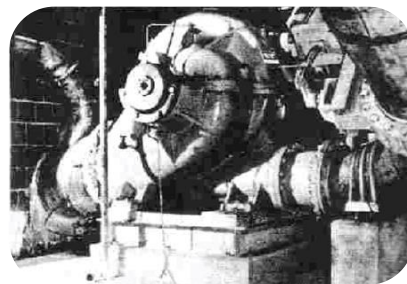

Pulp and Paper - fan pumps, white water, raw water, weak black liquor, primary cleaner.

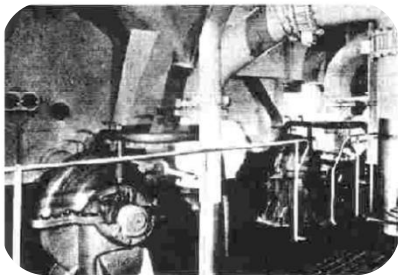

Marine - Cargo unloading

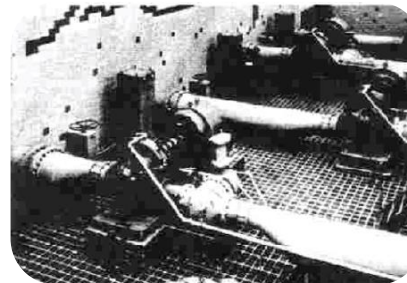

Water works - raw water, low and high lift, backwash

LN Series

Sizes: 6" to 42"
 Capacity: to 12,500 m³/h
 Heads: to 190 metres

A rugged, single stage, double volute horizontal split case pump built for sustained efficiency and economy.

Nomenclature

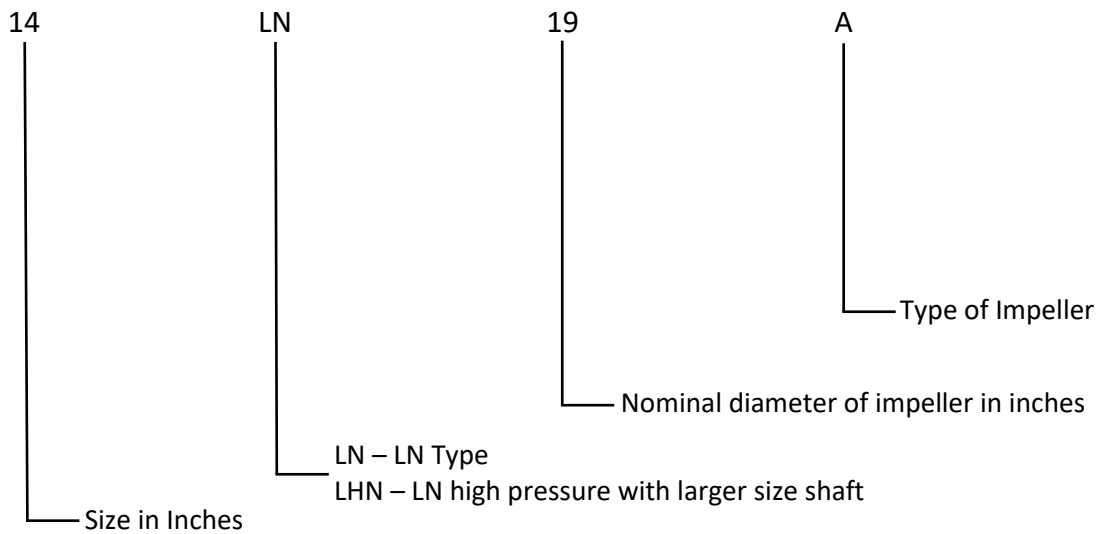

Features

- Axially split case design
- Range from 20m³/hr to 600m³/hr
- Two stage pump
- Single suction twin volute casing design – closed type impeller
- Suction/discharge branches integrally cast with casing

Advantages

- Balanced axial loading
- Can operate almost at shut-off capacity without excessive deflection
- Rugged design and high efficiency
- Ease of maintenance
- Low noise and vibration

LN Series Advanced Design Features

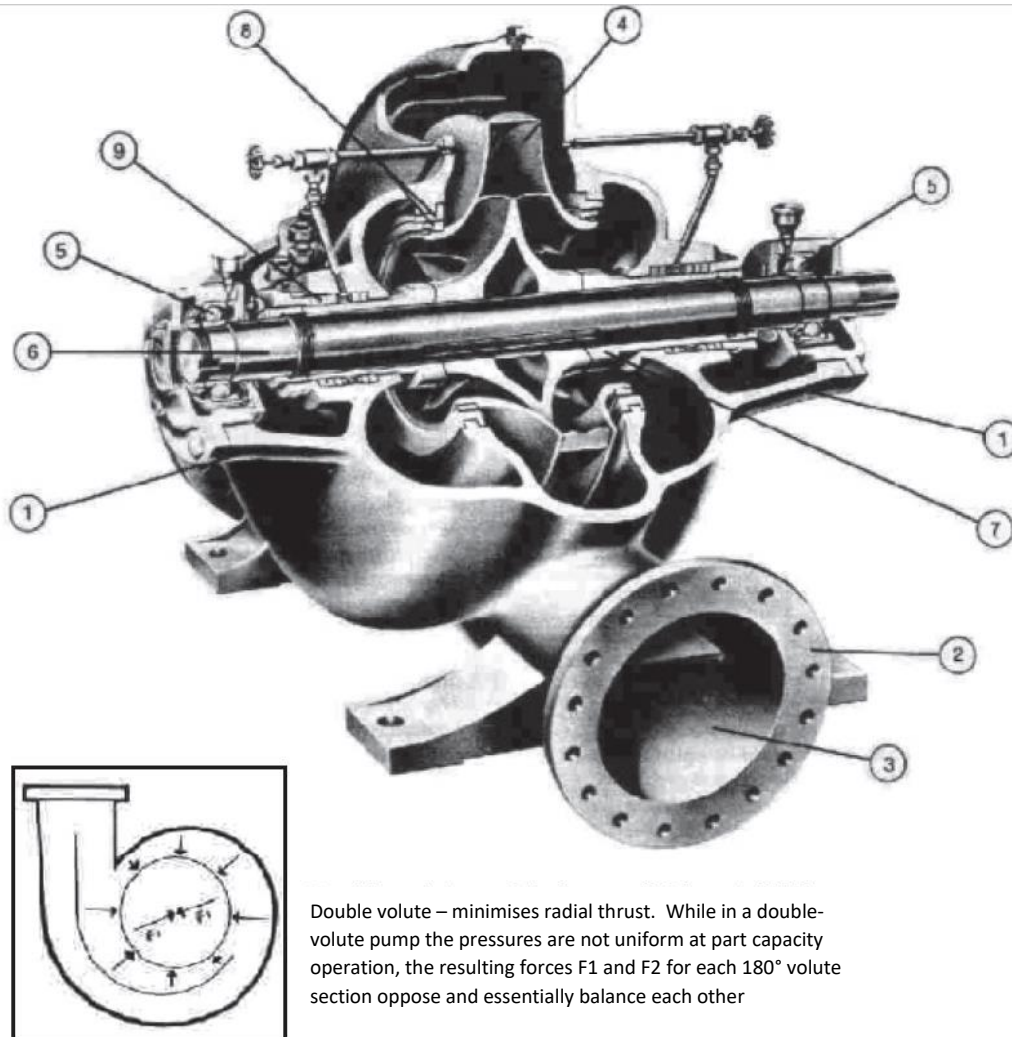

Double volute – minimises radial thrust. While in a double-volute pump the pressures are not uniform at part capacity operation, the resulting forces F_1 and F_2 for each 180° volute section oppose and essentially balance each other

1. Bearing Brackets are cast integral with the casing – assuring perfect alignment
2. Suction and discharge connections are all on the same centre line – simplifying piping
3. Smaller discharge diameter – reduces the cost of piping and valves – allowing more compact installation.
4. All impellers are dynamically and statically balanced – for vibration free operation.
5. Interchangeable line and thrust bearings, conservatively rated at 40,000 hours “plus” bearing life – guarantee minimum life at – minimum maintenances cost. Either oil or grease lubrication available.
6. Rigid shaft combined with double volute casing – results in low shaft deflection at operating points. Low deflection reduces packing wear ring, wear and bearing loading, which ultimately results in sustained efficiency and economy of operation.
7. Packing sleeve is keyed to shaft and held in place by separate shaft nut. This feature provides the greatest simplification of sleeve replacement. Sleeves are sealed to shaft by an “O” ring to prevent leakage and subsequent erosion. 11/13 chrome sleeves are available for extended sleeve life on packing.
8. Casing and impeller wearing rings are standard and renewable on all pumps.
9. Stuffing box option. Packing or mechanical seals can be furnished.
10. Many sizes available with side or bottom suction – for installation flexibility.

Typical LN Pump Specifications

General (LN type)

The pump shall be a horizontal, single stage, double suction, double volute axially split case centrifugal pump. The suction and discharge nozzles shall be integrally cast in the lower half of the casing and on the same horizontal centreline. The pump shall have a side suction and discharge equal to the LN type pump.

Conditions of Service

The pump shall be designed for pumping for the following conditions of service:

Design Capacity Total head in feet Suction head or lift

Minimum operating head Maximum operating head Minimum shut-off head Pump discharge size

Maximum rpm

Driver type

Shaft and Sleeves

The pump shaft shall be of heat treated steel, accurately machined and ground over its entire length. The shaft shall be protected from wear and erosion in the pump and stuffing box by removable SS sleeves. These sleeves are to be keyed to the shaft with the same key extended from the impeller and held in place by separate SS shaft nuts. The sleeves shall be provided with "O" rings to prevent leakage between the shaft and sleeves.

Bearings

The pump bearings shall be of the heavy duty dingle row anti-friction type, arranged for (grease/oil) lubrication. The bearings shall be adequately sized for long life with- out the addition of external cooling. The inboard and outboard bearings of the pump shall be interchangeable. Removable bearing housings shall be bolted and dowelled to bearing brackets that are cast integrally with the pump's lower half casing.

Baseplate

The pump and driver should be mounted on one piece of fabricated steel baseplate

Flexible Coupling

The pump shall be directly connected to its driver by means of a flexible coupling.

Casing

The casing shall be of close-grained cast iron and shall be tested at a hydrostatic pressure (table on next page). The bearing bracket shall be cast integrally with the lower half casing. The upper half casing shall be fitted with lifting lugs or eye bolts. The casing shall be provided with all necessary vents, drain plugs and suction and discharge gauge connections. The suction and discharge connections shall be (Cl. 150 ANSI std. flanges).

Impeller

The impeller shall be close grained cast iron and of the double suction type. The impeller shall be dynamically balanced and mounted on the shaft with a single key which extends beyond the impeller hub locking the impeller and the shaft sleeves against rotation on the shaft.

Wearing Rings

The casing shall be fitted with C.I. wearing rings designed to provide a smooth flow of water into the impeller eye. The casing ring shall be provided with a positive means of preventing rotation. The impeller shall also be fitted with removable C.I. wearing rings and held in place by set screws.

This is a standard specification for a water pump. For other applications, consult your local WPIL representative

Range Chart of LN Series Pumps

Horizontal Split Case Pump LN Series Coverage Chart

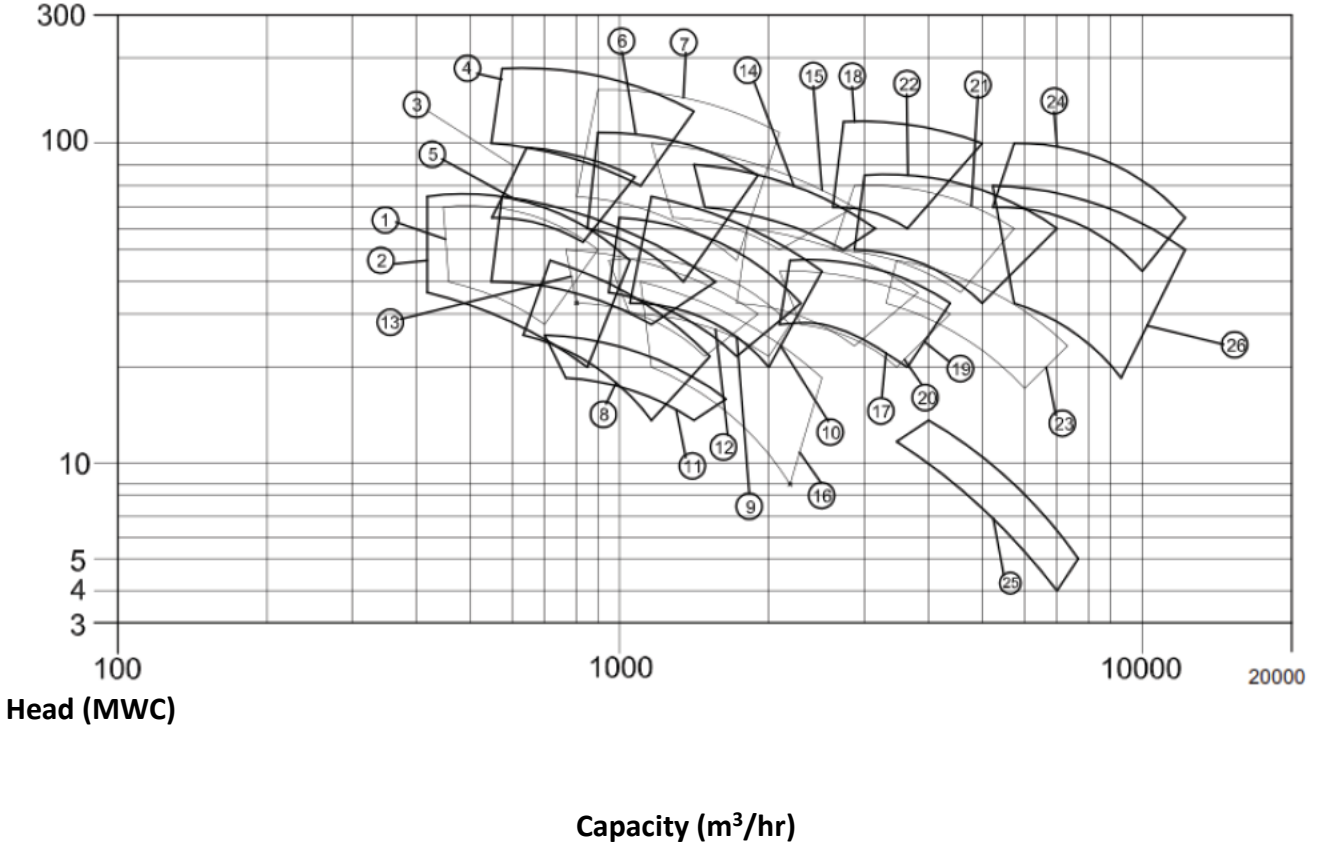

1	8LN18A at 1480 rpm	14	12LNH21A at 1480 rpm
2	8LN18C at 1480 rpm	15	12LNH21B at 1480 rpm
3	8LN21C at 1480 rpm	16	14LN19A at 985 rpm
4	8LN29B at 1480 rpm	17	16LN23C at 985 rpm
5	10LN18A at 1480 rpm	18	16LN23C at 985 rpm
6	10LN22A at 1480 rpm	19	20LN26A at 985 rpm
7	10LN26A at 1480 rpm	20	20LN28B at 735 rpm
8	12LN14A at 1480 rpm	21	20LN28B at 985 rpm
9	12LN17A at 1480 rpm	22	20LN28C at 985 rpm
10	12LN17B at 1480 rpm	23	24LN34A at 735 rpm
11	12LN21A at 735 rpm	24	24LN42A at 735 rpm
12	12LN21A at 985 rpm	25	30WLN30C at 590 rpm
13	12LN21B at 985 rpm	26	30LN41C at 590 rpm

Dimensions of LN Series Pumps

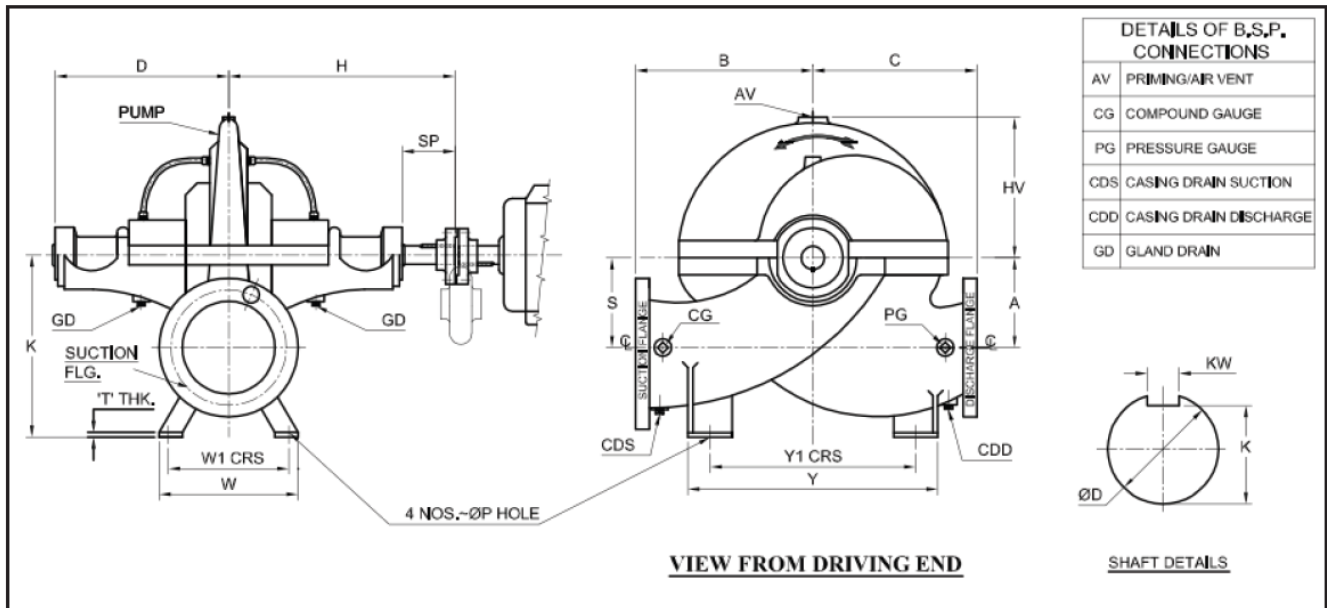

Pump Model	Suction Size	Disch. Size	A	B	C	D	SP	HV	H	K	P	W	W1	Y	Y1	Ø SD	Weight in Kg (*App)
8 LN 18	300	200	279	559	419	540	134	325	664	457	28	660	533	572	457	57.15	660
8 LN 21	350	200	378	560	508	578	170	365	760	552	30	670	500	635	520	80	850
8 LN 29	350	200	440	620	450	575	170	463	760	640	32	650	580	635	520	80	1150
10 LN 18	300	250	318	533	483	529	140	354	670	495	32	686	533	635	508	54	720
10 LN 22	350	250	353	706	522	629	170	411	821	572	32	650	580	736	584	80	920
10 LN 26	350	250	445	675	495	575	170	510	760	650	32	659	580	740	610	80	1240
12 LN 14	350	300	334	535	420	490	140	340	630	525	24	620	510	620	520	50	910
12 LN 17	400	300	356	610	533	584	158	356	733	584	30	737	584	737	610	57.15	990
12 LN 21	400	300	381	724	572	627	180	425	806	622	30	737	584	737	610	68.85	1160
12 LN 21	400	300	381	724	572	627	180	425	832	622	30	737	584	737	610	82.55	1170
14 LN 19	400	350	410	700	500	560	140	440	700	700	35	700	560	700	570	57	1080
16 LN 23	500	400	507	840	670	731	180	527	987	820	32	860	710	1030	880	82.55	1930
16 LN 35	600	400	560	865	813	770	225	660	995	927	42	1096	1016	1216	1016	114.3	3140
20 LN 26	700	500	550	800	750	760	230	630	1030	970	42	1000	860	1240	1040	90	2470
20LN 28	600	500	545	940	813	790	190	580	1008	902	35	1014	914	962	762	100	3200
24 LN 34	750	600	700	1150	875	912	180	705	1156	1190	39	1190	970	1190	970	105	5020
24 LN 42	900	600	724	1245	1041	930	267	838	1197	1219	42	1372	1172	1372	1172	139.7	6350
30 WLN 30	750	750	682	1116	810	610	190	810	107	1162	35	880	760	1080	840	94	5350
30 LN 41	900	750	812	1320	1220	984	272	825	1256	1320	42	1470	-	1676	-	139.7	8200

* Approximate only. Will vary with kW/hp, size, type and maker of motor involved

All dimensions are in mm are for preliminary use only

Pumps of either rotation can be supplied.

Contact Sterling Pumps for verification of measurements

Materials of Construction

Fittings	Standard Fitted	All Iron Fitted	All Bronze Fitted	S Steel Fitted
Casing	Cast Iron	Cast Iron	Bronze	S Steel
Impeller	Cast Iron	Cast Iron	Bronze	S Steel
Impeller Rings	Cast Iron	Cast Iron	Bronze	S Steel
Casing Rings	Cast Iron	Cast Iron	Bronze	S Steel
Glands	Cast Iron	Cast Iron	Bronze	S Steel
Shaft	Steel	Steel	S Steel	S Steel
Shaft Sleeve	S Steel	Steel	S Steel	S Steel
Shaft Nuts	S Steel	Steel	S Steel	S Steel
Seal Cage	Bronze	Bronze	Bronze	S Steel
Bearing Housing	Cast Iron	Cast Iron	Cast Iron	Cast Iron
Bearings	SKF or Equal Anti – Friction Type			
Packing	Graphite Impregnated Asbestos			
Base Plate	Fabricated Steel			
Coupling	Pin Bush			

Optional pumps in higher alloys like duplex steel etc. can be supplied

Flange Data	ANSI B 16.5 CLS. 150											
	6	8	10	12	14	16	18	20	24	30	36	42
Nozzle Size (inch)	6	8	10	12	14	16	18	20	24	30	36	42
O.D Flange (mm)	279	343	406	483	535	595	635	700	815	984.2	1168.4	1346.2
Flange Thickness (mm)	25.5	29	30.5	32	35	37	40	43	48	54	60.3	66.7
No. of Bolt Holes	8	8	12	12	12	16	16	20	20	28	32	36
Size of Bolt Holes (mm)	23	23	26	26	29	29	32	32	35	34.9	41.3	41.3
Bolt Circle Diameter (mm)	241.3	298.4	361.9	431.8	467.2	539.7	577.8	635	749.3	914.4	1085.8	1257.3

Engineering Data

Pump Size and Type	Suction Size	Discharge Size	Construction	Maximum rpm	Shaft Diameter		Shaft Span between Bearings	Stuffing Box Data					
					At impeller	At coupling		O D sleeve	ID Box	Depth of Box	Size of Packing	No. Rings per Box	Width Seal Cage
8 LN 18	300	200	DV	2300	82.6	57.2	942.3	101.6	133.4	119.0	15.88	5	32
8 LN 21	350	200	DV	1800	95.2	80.0	1007.0	114.3	146.0	120.0	15.88	5	32
8 LN 29	350	200	DV	1800	95.2	80.0	1002.0	114.3	146.0	119.0	15.88	5	32
10 LN 18	300	250	DV	1800	76.2	54.0	937.0	88.9	120.7	119.0	15.88	5	32
10 LN 22	350	250	DV	1500	95.2	80.0	1125.5	114.3	146.0	119.0	15.88	5	32
10 LN 26	350	250	DV	1500	95.2	80.0	1005.0	114.0	146.0	119.0	15.88	5	32
12 LN 14	350	300	SV	1800	76.2	50.0	1041.0	88.9	120.7	119.0	15.88	5	32
12 LN 17	400	300	DV	1500	82.6	57.2	1028.7	101.6	133.4	119.0	15.88	5	32
12 LN 21	400	300	DV	1500	95.3	69.9	1122.7	114.3	146.0	119.0	15.88	5	32
12 LNH 21	400	300	DV	1500	95.3	82.6	1129.0	114.3	146.0	119.0	15.88	5	32
14 LN 19	400	350	SV	1500	80.0	57.0	997.0	95.0	120.0	93.0	19.05	5	25
16 LN 23	500	400	SV	1000	95.0	86.2	1205.0	114.0	152.0	153.0	15.88	5	38
16 LN 35	600	400	DV	1000	139.7	114.3	1358.9	165.1	203.2	142.9	19.05	5	38
20 LN 26	700	500	DV	1000	120.0	90.0	1338.0	152.4	190.5	144.0	19.05	5	38
20LN 28	600	500	DV	1000	127.0	92.1	1389.4	152.4	190.5	142.9	19.05	5	38
24 LN 34	750	600	DV	750	118.0	105.0	1557.0	140.0	178.0	148.0	19.05	5	38
24 LN 42	900	600	DV	750	165.1	139.7	1612.9	190.5	228.6	142.9	19.05	5	38
30 WLN 30	750	750	SV	750	111.0	94.0	168.0	130.0	170.0	140.0	20.00	5	38
30 LN 41	900	750	DV	600	177.8	139.7	1737.4	203.2	241.3	142.9	19.05	5	38

Pump Size and Type	Casing Thickness (3)	Maximum Pressure Rating (kg/cm ²)			SKF Ball Bearing No.		GD2 of Rotor kg.m ²	Bare Pump Weight
		Hydrostatic Test	Maximum Suction	Maximum Discharge	Outboard	Inboard		
8 LN 18	16.00	21	9.0	14	6212	6212	6.5	660
8 LN 21	16.00	16	9.0	10	6217	6217	10.3	850
8 LN 29	16.00	16	9.0	10	6217	6217	21.8	1150
10 LN 18	16.00	21	9.0	14	6211	6211	6.0	720
10 LN 22	16.00	16	9.5	11	6217	6217	6.0	920
10 LN 26	16.00	16	9.5	11	6217	6217	20.9	1240
12 LN 14	16.00	16	9.0	11	6211	6211	4.5	910
12 LN 17	19.00	16	9.0	11	6214	6214	7.9	990
12 LN 21	19.00	16	9.0	11	6315	6315	17.7	1160
12 LNH 21	19.00	16	9.0	11	6217	6217	17.8	1170
14 LN 19	14.00	16	9.0	11	6213	6213	6.2	1080
16 LN 23	18.00	16	9.0	11	6317	6317	21.1	1930
16 LN 35	25.00	16	9.0	11	6224	6224	142.8	3140
20 LN 26	12.00	16	9.0	11	6222	6222	52.8	2470
20LN 28	25.00	16	9.0	11	6319	6319	59.2	3200
24 LN 34	21.00	14	5.0	9	6222	6222	130.6	5020
24 LN 42	28.58	14	5.0	9	6228	6228	212.5	6350
30 WLN 30	17.00	7	3.0	5	6319	6319	92.3	5350
30 LN 41	28.58	11	5.0	7	6328	6328	234.0	8200

Features, Functions and Benefits

SL No.	Feature	Function	Benefit
1	Axially split casing.	Secures good access to all parts	Eliminates need of distributing the pipe connection.
2	Semi – circular flange with adjusting bolt for bearing housing.	Assures perfect alignment.	Reduces wearing ring wear.
3	Side suction and side discharge nozzles.	Are on the same centreline.	Simplifies piping arrangement.
4	Double volute and symmetrical casing.	Minimises radial and axial load.	Reduces seal and bearing wear.
5	Guide vane.	Insures uniform flow into the impeller eye.	Reduces vortexing and improves pump performance at reduced flow.
6	Low galling material casing and impeller rings.	Can be replaced. Close clearance between impeller ring and casing ring.	Eliminates the need to replace impeller or casing if wear occurs. Able to obtain high efficiency.
7	Mechanical seal.	Cartridge type.	Easy to install, disassemble and maintain.
8	Stuffing box throat bushing (option).	Close clearance between bushing and shaft sleeve	Can increase stuffing box pressure - reduces box fluid flow into pumped liquid
9	Double suction impeller	Minimises NPSH required. Eliminates axial load.	Able to use smaller, higher speed pumps. Can use economical thrust bearing.
10	Dynamically balance impeller.	Eliminates vibration of impeller.	Increases seal and bearing life.
11	Short span bearings.	Minimises shaft deflection.	Reduces ring and seal wear.
12	Duplex double row 40 Deg. angular contact thrust bearing (option).	Carries greater load and minimises axial movement of shaft.	Extends life of thrust bearing and reduces seal wear.
13	Replaceable shaft sleeve.	Resists wear from Mechanical seal and packing.	Protects shaft from damage.
14	Shaft sleeve extends through seal gland.	Can determine seal or sleeve gasket leaking.	Know whether seal must be replaced without stopping pump.
15	Keyed impeller, distance sleeve and shaft sleeve.	Prevent rotation of impeller and sleeve on shaft.	Reduce shaft wear and loss of performance
16	Shaft deflector between stuffing box and bearing bracket.	Prevents pumpage from entering bearing bracket	Eliminates bearing failure cause by diluted oil.
17	Flood oil lubrication with constant level oiler.	Supplies oil automatically to bearing.	Maintenance free for bearing lubrication.
18	Bearing housing, no- sparking oil baffle (option).	Replaceable, no-sparking oil baffle that prevents heat generation on shaft and loss of bearing oil.	Reduces chance of shaft breakage and bearing failure.
19	Wide selection of bearings.	Provide bearing tailored to application requirements with respect to rotor support and axial and radial force absorption.	Trouble free operation with broadest range of applications.
20	Spacer coupling.	Allows removal of bearing and mechanical seal.	Eliminates need to disassemble upper half casing or move driver when repairing.
21	Coupling guard.	Encloses coupling and pump driver shaft.	Protects workers from rotating parts.
22	Fabricated steel – reduces box fluid flow into pumped liquid, late with drain pan.	Rigid to withstand distortion.	Reduces misalignment problems.



Sterling Pumps Pty. Ltd.
14 Sharnet Circuit
Pakenham

Phone: 03 5941 3400

Fax: 03 5940 2645

sales@sterlingpumps.com.au

